

THERMOPLAN B&W4 COMPACT CTM2 + UNDERCOUNTER FRIDGE

Outstanding coffee quality at the touch of a button. Compact Swiss made modularity.

FEATURES + BENEFITS

- Compact in size without compromise – the Black&White 4c is the world's most compact bean-to-cup machine at this level of performance. It's simple to use, delivers consistently exceptional coffee, all while having a footprint the size of an A4 piece of paper.
- Barista-level micro-foam – an exceptional espresso deserves consistent, stable and perfectly textured milk. It's guaranteed thanks to adjustable micro-foam settings. The patented milk technology delivers without the requirement for an annual Pressure Vessel Inspection.
- Clever modularity – all functions are set up in two front-end exchangeable modules. Maintenance work is performed exclusively on these, minimising downtime and engineer time on site.
- Key features – 13amp power supply, Pressure Vessel Inspection not required, made in Switzerland, automated cleaning process, exchangeable module system and low noise output.



KEY STATISTICS

| **Product:** Coffee. Tea. Milk

| **Power (watts):** 2800

| **Milk:** Auto

Product code: 10004

THERMOPLAN
B&W4 COMPACT CTM2 +
UNDERCOUNTER FRIDGE

Outstanding coffee quality at the touch of a button. Compact Swiss made modularity.

CAPACITY AT PEAK







CAPACITY PER DAY



RECOMMENDED PRODUCTS

Quarterly Cleaning Pack
Product code: CLESCH0591

LEC Fridge
Product code: 9171
Dimensions w x d x h (mm):
470 x 604 x 500
Power (watts): 13A standard
3-pin sockets
Important: Ventilation
grill required

Water connection	2-4 BAR isolated 15mm feed, 3/4" BSP screw fitting	
Filter type	Brita Purity 600/1200 C50	
Waste	1.5" downpipe to P-trap, minimum length 8"	
Power (watts)	2800	
Power requirements	1 x 230Vac 13A standard 3-pin socket	
Breaker	B	
Drinks dispensed simultaneously	N/A	
Milk option	Auto	
Product	Coffee. Tea. Milk	
Weight (kg)	40	
Dimensions w x d x h (mm)	230 x 600 x 650	

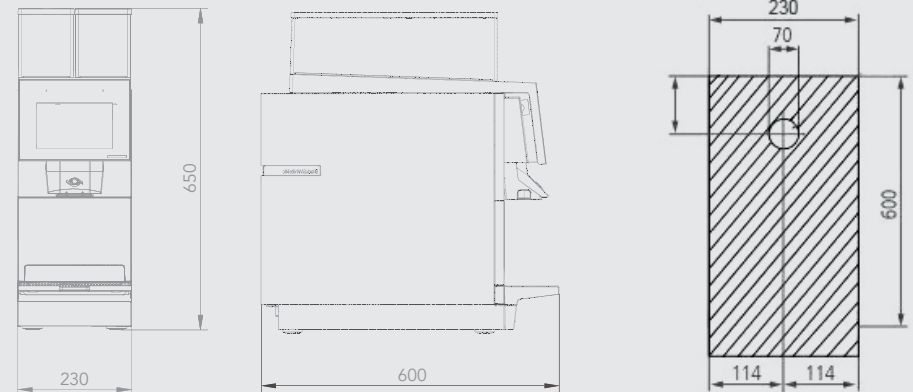

Hole is required through the counter